



VersaClipper 1000™ Single-Head Clipping Machine

An easy way to clip your curved rail without staple-on clips.

The VersaClipper 1000™ is a low-cost, high-output solution to your clipping needs. This versatile machine clips both straight and curved rails, and the adjustable anvil allows you to clip rail heights from 5/8" to 3-1/4". The convenient 1,500 clip roll is easy to load. The VersaClipper 1000 is easy to operate; any operator can be productive after only a few minutes of instruction. You won't find another machine like the VersaClipper 1000 on the market. Innovation, simplicity of design, durability, productivity, and unmatched customer service make the VersaClipper 1000 the perfect choice for your clipping needs.



YOUR WORLDWIDE FASTENER SUPPLIER

VertexFasteners.com

VersaClipper 1000™ Single-Head Clipping Machine

Outstanding Features to Increase Production

- Adjustable anvil. Can accommodate rails from 5/8" to 3-1/4" in height.
- 1,500 clips per roll. 50% more clips per load than competitive machines means less reloading, increased productivity.
- Easy operation. Any operator can be trained in minutes and the results will be consistent from operator to operator.
- Economic functions. The all-pneumatic VersaClipper 1000 uses no electricity. The VersaClipper 1000 applies clips more accurately and efficiently than hand application. Fewer moving parts means low service costs, greater productivity, and increased reliability.
- Service and technical support. Vertex Fasteners is committed to providing our customers with world-class customer service and support. Our dedicated regional sales/service technicians are Vertex employees. They know the product, the business, and their customer, and are there to serve you. Vertex also has a well-trained staff of customer service, production, and engineering professionals that are ready and able to assist you.

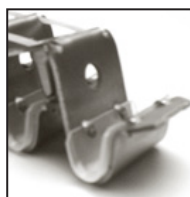
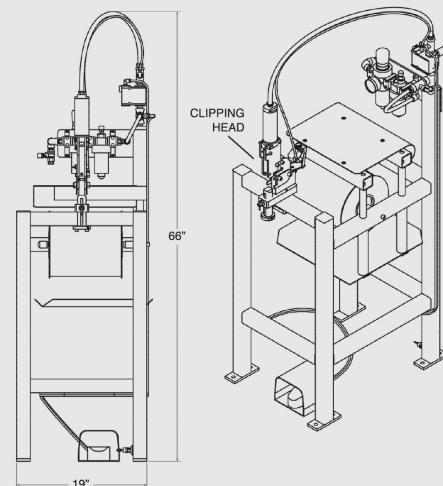
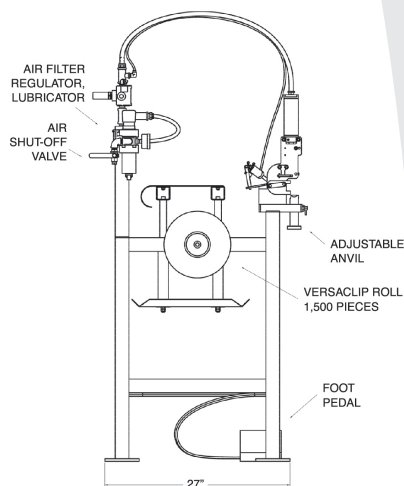

The 1000 series uses the all-steel VersaClip™ featuring Vertex's patented polycord collation technology, high-profile upturned edge, and extended polypropylene liner. Its all-in-one design works for both back and seat rails.

Clip Specifications

Part No: RV-1
Roll Qty: 1,500 Clips
Pallet Qty: 96,000 Clips

Clip Delivery

2,000-2,500 clips per hour

Air Pressure

60-100 psi (4.1-6.9 bar)

Floor Space Required

27' x 19' (1m x 4m)

Rail Dimensions Accepted

Height: 5/8" to 3-1/4" (15mm to 82.55mm)

Vertex products are covered by one or more of the following Patent Numbers: 5,303,821; 5,833,064; 6,055,716.



YOUR WORLDWIDE FASTENER SUPPLIER

address | 1798 Sherwin Avenue
Des Plaines, IL 60018 U.S.A.

phone | 847.768.6139
fax | 847.768.7192

web address | VertexFasteners.com