

FaceClipper 4000

Semi-Automatic,
Multi-Tool
Clipping Machine

The efficient way
to handle all your
clipping needs.

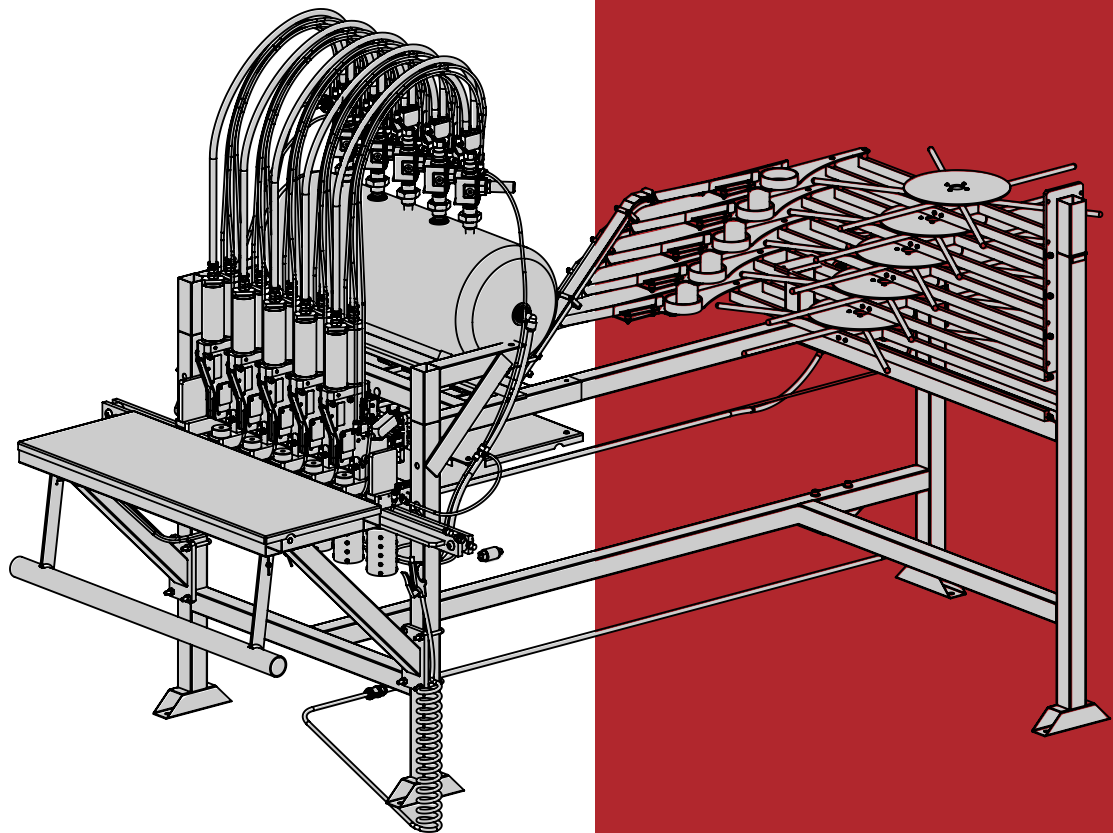

YOUR WORLDWIDE FASTENER SUPPLIER

VertexFasteners.com

FaceClipper 4000

Semi-Automatic, Multi-Tool Clipping Machine

Fast, Economical Clipping

- **Up to six clipping heads.** All heads fire simultaneously, letting you clip a whole rail in one second, installing clips four times faster than by hand.
- **Easy operation.** An operator is productive with proper instruction to install up to six clips at one time. Clips are reliably spaced and the results will be consistent from operator to operator.
- **Versatile set ups.** The clipping heads move from side to side, in and out, and swivel to accommodate different clipping patterns, including curved rails.
- **Easily accommodate a variety of rail sizes.** The adjustable-height clipping heads can accommodate rails from 5/8" to 2" in height.
- **Semi-automatic function.** Uses only compressed air to operate, meaning you have fewer moving parts to attend to.
- **Service and technical support.** Vertex Fasteners is committed to providing our customers with world-class customer service and support. Our dedicated regional sales/service technicians are Vertex employees. They know the product, the business, and their customer, and are there to serve you. Vertex also has a well-trained staff of customer service, production, and engineering professionals that are ready and able to assist you.



The FaceClipper 4000 uses 19-gauge, high-strength, all-steel embossed face clips that provide strength, durability, and holding power.

- Integral nails enter rail at different points to prevent splitting and provide superior holding power.
- High-profile, upturned edge to provide an excellent target for easy spring-up and hammer closing.
- Extended polypropylene liner extends past the ends of the clip to prevent metal-to-metal noise.
- Liner and spring locks mechanically lock liner in place and accurately position sinuous springs in clip.



YOUR WORLDWIDE FASTENER SUPPLIER

address | 1798 Sherwin Avenue
Des Plaines, IL 60018 U.S.A.

phone | 847.768.6139
fax | 847.768.7192

web address | VertexFasteners.com