

FaceClipper 2000

Semi-Automatic
Clipping Machine

The fast, versatile
clipping solution.

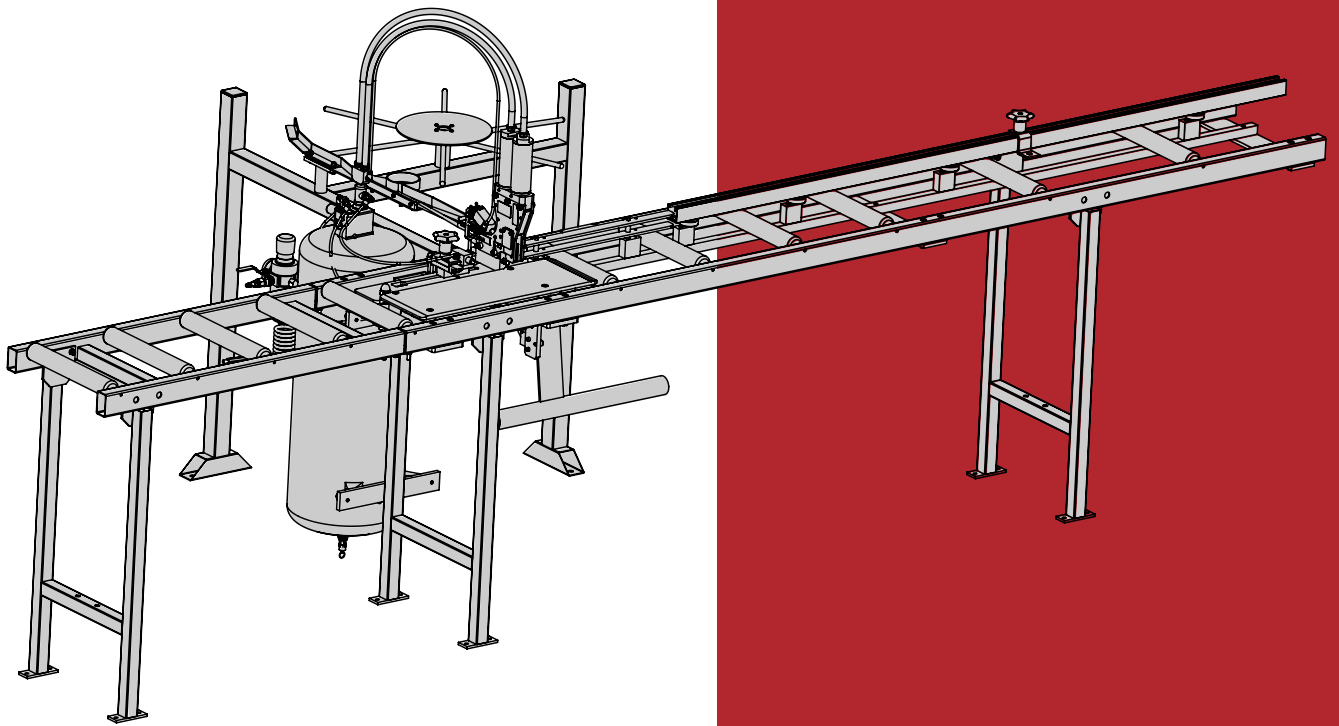

YOUR WORLDWIDE FASTENER SUPPLIER

VertexFasteners.com

FaceClipper 2000

Semi-Automatic Clipping Machine

The FC2000 clipping machine is a semi-automatic and versatile solution to your clipping needs, installing clips into furniture rails for sinuous spring attachment.

- Fast rail clipping. Installs clips consistently three times faster than by hand.
- Easily accommodate a variety of rail sizes. The adjustable-height clipping head can accommodate rails from 5/8" to 2" in height.
- Removable entry guide. Clips curved and irregularly shaped rails of hardwood, softwood, plywood, and composites in lengths up to 95".
- Easy operation. An operator is productive with proper instruction. The FC2000 installs clips reliably spaced from 2" to 8" and operates on only compressed air.
- Economic functions. The semi-automatic FaceClipper 2000 uses no electricity. Fewer moving parts means low service costs, greater productivity, and increased reliability.
- Service and technical support. Vertex Fasteners is committed to providing our customers with world-class customer service and support. Our dedicated regional sales/service technicians are Vertex employees. They know the product, the business, and their customer, and are there to serve you. Vertex also has a well-trained staff of customer service, production, and engineering professionals that are ready and able to assist you.



The FaceClipper 2000 uses 19-gauge, high-strength, all-steel embossed face clips that provide strength, durability, and holding power.

- Integral nails enter rail at different points to prevent splitting and provide superior holding power.
- High-profile, upturned edge to provide an excellent target for easy spring-up and hammer closing.
- Extended polypropylene liner extends past the ends of the clip to prevent metal-to-metal noise.
- Liner and spring locks mechanically lock liner in place and accurately position sinuous springs in clip.



YOUR WORLDWIDE FASTENER SUPPLIER

address | 1798 Sherwin Avenue
Des Plaines, IL 60018 U.S.A.

phone | 847.768.6139
fax | 847.768.7192

web address | VertexFasteners.com