

# C-RING TOOL VA0392 OPERATING MANUAL

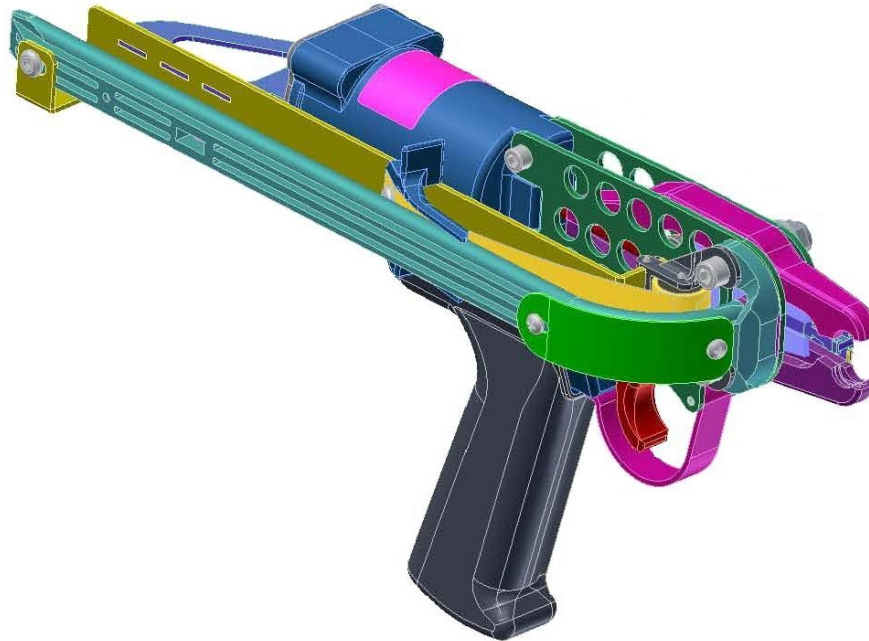

1798 Sherwin Avenue  
Des Plaines, IL 60018 U.S.A.  
EMAIL: [vertex@leggett.com](mailto:vertex@leggett.com)  
PHONE: 847-768-6139 FAX: 847-768-7192

## Operational Instructions for Vertex C-Ring Tool VA0392

**Vertex Fasteners** is committed to providing our customers with world-class customer service and support. Our dedicated regional sales/service technicians are Vertex employees. They know the product, the business, and their customers, and are there to serve you. Vertex also has a well-trained staff of customer service, production and engineering professionals that are ready and able to assist you.

This and other manuals are available on our website: [WWW.VERTEXFASTENERS.COM](http://WWW.VERTEXFASTENERS.COM)

### MAINTENANCE

Most problems with tools are a result of:

1. Normal wear and tear to components due to high usage.
2. Lack of proper lubrication.
3. Dirt or water that may enter the tool via air lines.
4. Defective rings.

### LUBRICATION

1. The **C-Ring tool VA0392** is designed for long, trouble free use with **minimal in-line lubrication**. (If an in-line lubricator is used, it should be set at a minimal rate of flow.)
2. When lubricating tool, **Pneumatic Fastening Tool Oil, Vertex part number VC0340** is recommended. When oiling, a couple of drops of oil should be placed through the airline fitting. Excess oil in tool will attract dirt, lint, and the tape used to collate rings, preventing smooth operation. Cycle tool to expel excess oil.
3. When servicing or repairing tool a **high grade lithium grease, Vertex part number VH0214** is recommended for all o-rings and moving parts.

### AIR FILTER AND REGULATOR

1. The airline should always contain a filter and regulator unit to provide tool with a constant flow of clean, dry air. Moisture and contaminants entering tool will decrease the serviceable life of tool.
2. The regulator should be set between **70 and 90 psi (4.8 to 6.2 bar)**. **Never operate tool over 100 psi (6.9 bar)**.

### TIPS ON EXTENDING TOOL LIFE

1. Always use **Vertex brand fasteners** and always use **Vertex genuine parts** when replacing worn or broken parts. **Generic fasteners, and parts** may shorten tool life and **will void your tool warranty**.
2. Use tool at minimum amount of air pressure needed to do the work at hand. **Excess air pressure will reduce the life of tool**.
3. Keep tool clean and dry and always use **clean dry air**.
4. Avoid dropping tool, a primary reason for parts replacement.

## HELPFUL HINTS FOR FIELD SERVICE OF TOOL JAMS

**SAFETY FIRST** – Always disconnect tool from air supply before attempting to clear a jam or servicing tool.

The most common reason for jamming problems is worn parts. Common parts that see a lot of wear are the jaws, pusher assembly and the pusher spring.

**Note:** refer to correct tool schematic for location of parts and correct part numbers.

## TROUBLESHOOTING

### Inside diameter of ring too large after clinching

- Latch worn – replace latch
- Latch spring broken – replace latch spring
- Low power
  1. Air pressure too low – check air pressure setting
  2. Air leaks in supply hose – replace hose
  3. Air leak in tool – see repair section
- Worn jaws (helix, cam surface, bolt holes, jaw bushings) – replace jaws
- Worn rollers – replace rollers
- Defective rings –
  1. Wire too hard
  2. Rough surface
  3. Cut-off burrs
  4. Wrong rings. Return samples of rings to your Vertex Fasteners representative for testing.

### Inside diameter of ring too small after clinching

- Wrong jaws – replace jaws
- Jaw stops worn or polished off – replace jaws

### Ring points not entering opposite jaw (Figure A)

- Tip of jaw broken off – replace jaws
- Mismatched jaws
  1. Jaws should be replaced only in pairs
- Defective rings
  1. Points not equal
  2. Ring not symmetrical
  3. Cut-off burrsReturn samples of rings to your Vertex Fasteners representative for testing.
- Ring point not entering jaw A – Correct by chamfering tip of the helix that the ring is entering as shown in Figure B.
- Rings only curling in one jaw – replace jaws

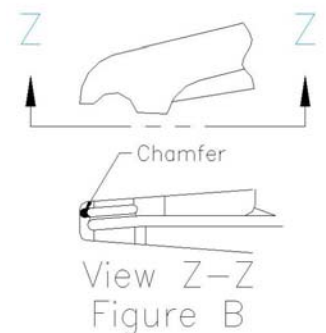
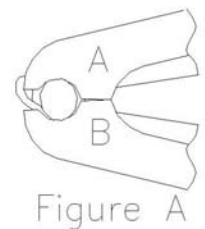

### Ring tear drops instead of forming

- Latch worn – replace latch
- Latch spring bent or broken (spring must hold latch tightly against end of side plate and against jaws) – replace latch spring
- Feeder blade worn – replace feeder blade
- Defective rings
  1. Burrs
  2. Twisted
  3. Not symmetrical
  4. Wrong rings. Return samples of rings to your Vertex Fasteners representative for testing.



### Rings jam

- Magazine
  1. Damaged magazine – replace magazine
  2. Too many shims (ring passes under shoe without raising shoe; no control of ring) – adjust see repair section
  3. Too few shims (ring must be forced under shoe which “bottoms out” and may deflect magazine) – adjust see repair section
  4. Worn shoe – replace shoe
  5. Frequent jamming can cause the shoe hole in the magazine to increase in size – replace the magazine
  6. Loose or lost rear magazine mounting screw (magazine is not supported properly) – tighten or replace mounting screw
- Damaged or bent rail – replace rail
- Pusher spring defective – replace spring
- Feeder blade worn, broken or bent – replace feeder blade
- Ring groove in jaw worn – replace jaw
- Defective rings
  1. Burrs
  2. Rings skewed on stick
  3. Rings out of line on stick
  4. Rings twisted
  5. Rings not symmetrical
  6. Poor tape to ring adhesion
  7. Wrong rings. Return samples of rings to your Vertex Fasteners representative for testing.

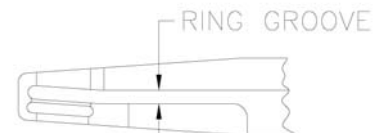

### Rings don't feed down magazine

- Pusher spring defective – replace spring
- Damaged magazine – replace magazine
- Damaged or bent rail – replace rail

- Damaged pusher – replace pusher
- Defective rings
  1. Undersized (tight on magazine)
  2. Burrs
  3. Rings twisted
  4. Rings skewed on stick
  5. Rings out of line on stick
  6. Poor tape to ring adhesion
  7. Wrong rings. Return tool and sample rings to your Vertex Fasteners representative for testing.

### **Ring spitting**

- Air pressure too high – verify air pressure
- Pusher spring loose – replace spring
- Magazine
  1. Damaged magazine – replace magazine
  2. Too many shims (ring passes under shoe without raising shoe; no control of ring) – adjust see repair section
  3. Too few shims (ring must be forced under shoe which “bottoms out” and may deflect magazine) – adjust see repair section
  4. Worn shoe – replace shoe
- Damaged or bent rail – replace rail
- Worn jaws – replace jaws (replace only in sets)
- Build up of material in jaw helix – remove build up of material
- Defective rings –
  1. Burr on outside curve of ring
  2. Rings skewed on stick
  3. Rings out of line on stick
  4. Rings not symmetrical
  5. Rings twisted opposite to jaw helix
  6. Wrong rings. Return samples of rings to your Vertex Fasteners representative for testing.

## Ring Defects

Vertex Fasteners Hog Ring Tools are designed to operate with rings manufactured to standard tolerances. Defective rings can be the cause of many ring-forming problems. Never use rings that are too loose or otherwise defective. Below are some examples of defects that can occur.

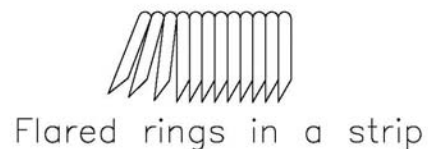
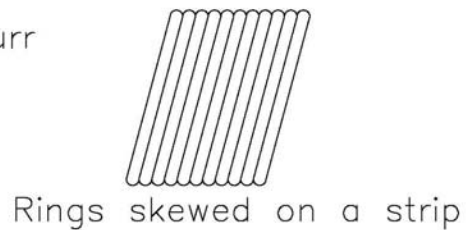
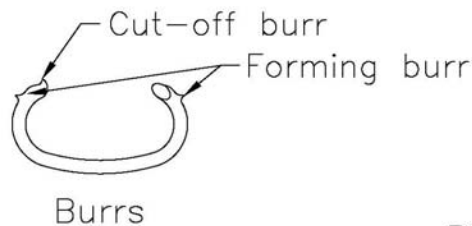
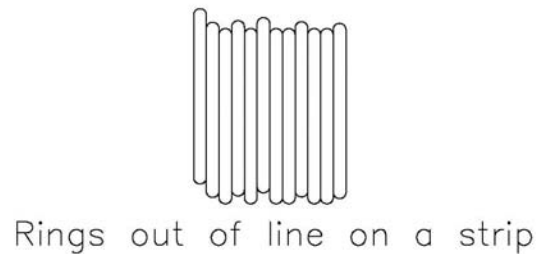

## REPAIR

**Note:** Mineral spirits is recommended for cleaning tool and parts. Do **not** allow rubber of handle to soak in mineral spirits as this will cause the rubber to swell over time and become loose on tool. Wipe off immediately, dry parts thoroughly before reassembly, use adequate ventilation.

## Jaws, magazine and pusher assembly



### To Disassemble

1. Remove screws **VH0489** from magazine **VC8112** and feeder guide rail **VC8119**.
2. Remove screws **VH0491** from rear of feeder guide rail.
3. Remove nylock nuts **VH0488**, washers **VH0221**, and latch spring **VC8158** from the jaw screws **VH0489**.
4. Remove jaw screws from tool this will allow magazine and pusher assembly, latch **VC8159** and jaws **VC8160** and **VC8161** with jaw bushings **VC8107** to be removed from tool.
5. Remove button head screw **VH0033** from rail and magazine.

### To Reassemble

1. Mount latch **VC8159** onto side plate opposite magazine.
2. Install jaw bushings **VC8107** into jaws **VC8160** and **VC8161**. Lubricate both jaws and bushings with lithium grease **VH0214** before installing.
3. Place jaws with bushings between side plates **VC8123**.
4. Slide magazine into position between spring spool bracket **VC8127** and side plate. Attach magazine assembly to rear of feeder guide rail using screw **VH0033** and blue **Loctite (243)**. But do **not** tighten completely.
5. Insert jaw screws **VH0489** through spring spool bracket, magazine, side plate, jaw bushing, side plate, latch spring and washers. Secure with nylock nuts. **Do not over tighten**, jaws must pivot freely.
6. Reattach feeder guide rail to rear of tool using screws **VH0491**.
7. Tighten button head screw **VH0033**.

## Piston and Piston Rod

### To Disassemble

1. Disassemble jaws, magazine and pusher assembly as outlined above.
2. Remove button head screw **VH0033** from trigger guard **VC8116**.
3. Remove (2) screws **VH0032** with nylock nuts **VH0490**.
4. Remove side plates, trigger guard, trigger and roll pins. **VC8123**, **VC8116**, **VC8106** and **VH0500**.

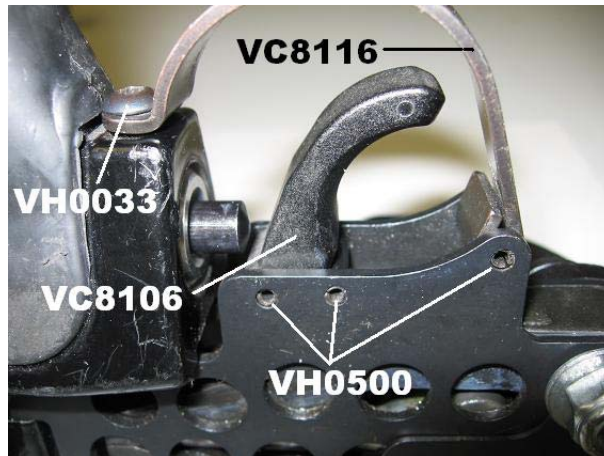

5. Remove (4) rollers **VC8139**.
6. Remove remaining (2) screws **VH0491** from rear of tool.

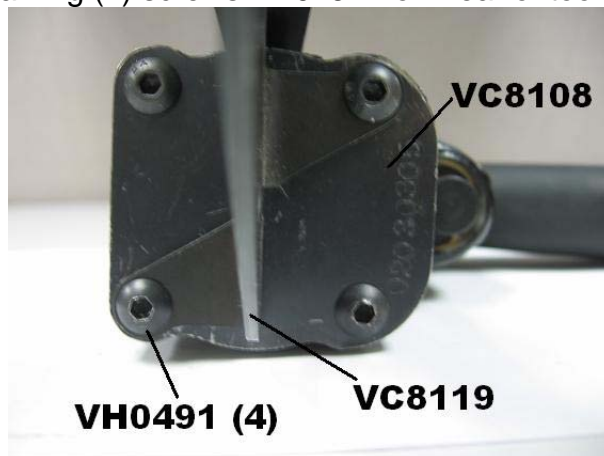

7. Remove end plate **VC8108** and o-ring **VH0496**.
8. Push piston rod **VC8138** towards rear of tool exposing piston **VC8162**.
9. Place tool into vise by clamping down on flat areas of piston rod (do not over tighten vise jaws).
10. Apply heat if needed to breakdown thread lock adhesive on threaded end of piston rod.



11. Remove piston **VC8162** with 9/16" open end or adjustable wrench.



12. Piston rod may now be removed from front of tool.
13. Remove piston rod o-ring **VH0464** from front of tool using o-ring pick.

### To Reassemble

1. Install o-ring **VH0464** into housing thru front of tool.
2. Slide piston rod **VC8138** into front of tool. Be careful not to damage o-ring **VH0464** when pushing piston rod into housing, use lubrication.
3. Place o-ring **VH0461** onto piston **VC8162**.
4. Lubricate piston o-ring liberally with grease **VH0214**.
5. Clean threads of piston rod and apply thread locker (**Loctite 2760**) to threads.
6. Slide piston with o-ring into housing end, aligning piston with piston rod. Be careful not to damage piston o-ring when inserting piston, use grease **VH0214**.
7. Use 9/16" open end or adjustable wrench to tighten piston while holding flat areas of piston rod.
8. Place o-ring **VH0496** into o-ring groove of housing.
9. Place end plate on rear of tool, properly aligned to housing and secure with (2) screws **VH0491**, leaving mounting area for feeder guide open.
10. Place rollers **VC8139** on roller pins **VH0499**. Grease will hold rollers in place while assembling rest of tool.
11. Slide side plates into place on housing (slight force may be used to place side plates onto housing).
12. Insert (2) screws **VH0032** from magazine side of tool and install nylock nuts **VH0490**.
13. Assemble trigger **VC8106** and trigger guard **VC8116** to side plates **VC8123** with (3) roll pins **VH0500**.
14. Reassemble jaws, magazine, pusher assembly and remaining hardware as outlined above.

## Pusher and pusher spring



### To Disassemble

1. Disassemble jaws, magazine and pusher assembly as outlined above.
2. Remove button head screw **VH0033** from pusher **VC8113** and spring **VC8109**.
3. Hold spring bracket **VC8127** in vise by the ears, it is not necessary to remove bracket from guide rail **VC8119**.
4. Drive slotted spring pin **VH0498** thru bracket and spring **VC8109**. Remove old spring.

### To Reassemble

1. Mount new spring **VC8109** onto spring bracket **VC8127** using slotted spring pin **VH0498**. Make sure spring is properly orientated (see diagram).
2. Attach spring **VC8109** onto pusher **VC8113** with button head screw **VH0033** (feed spring thru large opening in pusher).
3. Reassemble jaws, magazine and pusher assembly as outlined above.

## Valve



### To Disassemble

1. Remove retaining ring **VH0494**, deflector **VC8103** and spring **VH0506**.
2. Pull Valve rod **VC8111** straight back out of tool.
3. Replace (5) o-rings **VH0462**.
4. Remove spool **VC8105** by using long drift pin punch. From front of tool tap spool out of body of tool.
5. Replace (5) o-rings **VH0005**.

### To Reassemble

1. Use plenty of grease **VH0214** on spool **VC8105** and o-rings **VH0005**.
2. Insert spool into body from the rear, (see diagram for orientation) using deflector **VC8103** tap spool into place until flange of spool seats firmly in body.

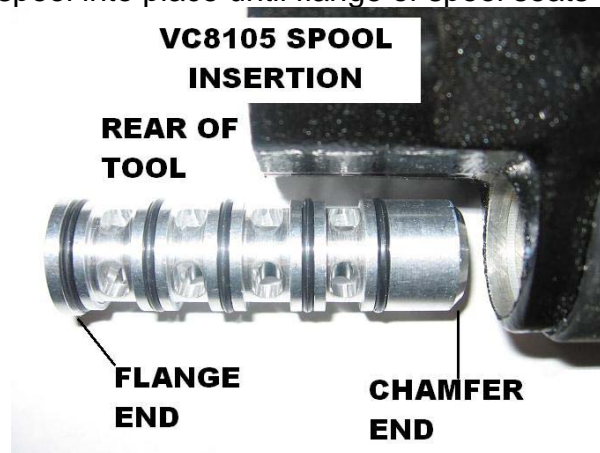

3. Use a small amount of grease **VH0214** on valve rod **VC8111** and o-rings **VH0462**.
4. Insert valve rod **VC8111** into spool **VC8105** until e-ring **VH0497** seats against the back of spool.

5. Replace spring **VH0506** onto end of valve rod **VC8111**.
6. Replace deflector **VC8103** and hold in place with retaining ring **VH0494**. Make sure that retaining ring snaps into internal groove of body.

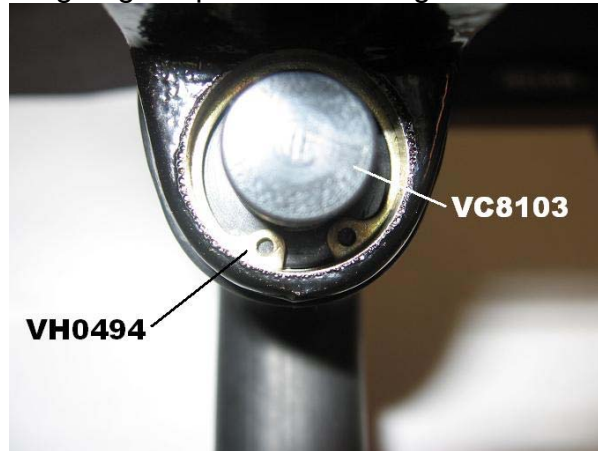

### **Converting to Left Hand Tool**

1. Remove (2) jaw screws **VH0489**, nuts **VH0488**, washers **VH0221**, latch spring **VC8158** and latch **VC8159**.
2. Remove (4) screws **VH0491**.
3. Remove magazine and pusher assembly.
4. Remove jaws **VC8160** and **VC8161** with bushings **VC8107** and replace back in opposite way.
5. Move latch **VC8159** to opposite side.
6. Place magazine and pusher assembly on other side.
7. Replace latch spring and fasteners.

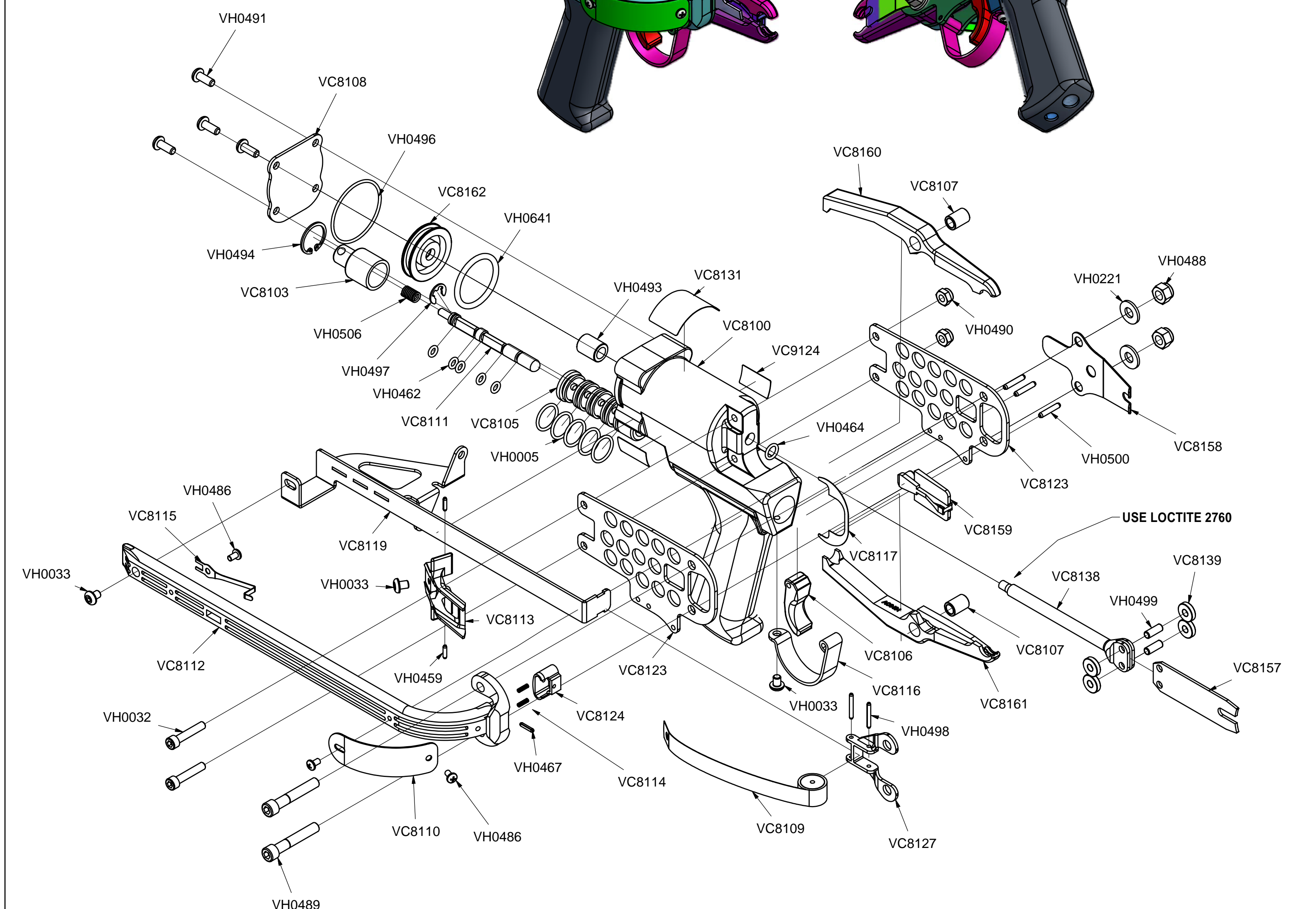

| PART # | DESCRIPTION                      | QT |
|--------|----------------------------------|----|
| VC8100 | HOUSING                          | 1  |
| VC8103 | DEFLECTOR                        | 1  |
| VC8105 | SPOOL                            | 1  |
| VC8106 | TRIGGER                          | 1  |
| VC8107 | BUSHING, JAW                     | 2  |
| VC8108 | PLATE                            | 1  |
| VC8109 | CONSTANT FORCE SPRING            | 2  |
| VC8110 | GUARD                            | 1  |
| VC8111 | VALVE ROD                        | 1  |
| VC8112 | MAGAZINE                         | 1  |
| VC8113 | PUSHER                           | 1  |
| VC8114 | SPRING                           | 2  |
| VC8115 | CLIP, ANTI-BACKUP                | 1  |
| VC8116 | GUARD, TRIGGER                   | 1  |
| VC8117 | SHIM, MAGAZINE, .010             | AR |
| VC8119 | RAIL, FEEDER GUIDE               | 1  |
| VC8123 | SIDE PLATE                       | 2  |
| VC8124 | SHOE, MAGAZINE                   | 1  |
| VC8127 | BRACKET, SPRING SPOOL            | 1  |
| VC8131 | LABEL, WARNING                   | 1  |
| VC8138 | ROD, PISTON                      | 1  |
| VC8139 | ROLLER                           | 4  |
| VC8157 | BLADE, FEEDER - EXTENDED         | 1  |
| VC8158 | SPRING, LATCH - EXTENDED         | 1  |
| VC8159 | LATCH - EXTENDED                 | 1  |
| VC8160 | JAW, UPPER - EXTENDED            | 1  |
| VC8161 | JAW, UPPER - EXTENDED            | 1  |
| VC8162 | PISTON                           | 1  |
| VC9124 | LABEL                            | 2  |
| VH0005 | O-RING, #016                     | -  |
| VH0032 | SHCS, 10 - 24 x 1                | 2  |
| VH0033 | BHCS, 10 - 32 x 1/4              | 3  |
| VH0221 | WASHER, 1/4                      | 2  |
| VH0459 | PIN, SLOTTED SPRING, 3/32 x 3/8  | 2  |
| VH0462 | O-RING, #008                     | -  |
| VH0464 | O-RING, 011                      | 1  |
| VH0467 | PIN, SLOTTED, 3/32 x 7/16        | 1  |
| VH0486 | PAN HEAD, 6 - 19 x 1/4           | 3  |
| VH0488 | NUT, NYLOCK, 1/4 - 28            | 2  |
| VH0489 | SHCS, 1/4 - 28 x 1 1/2           | 2  |
| VH0490 | NUT, NYLOCK, 10 - 24             | 2  |
| VH0491 | BHCS, 10 - 24 x 1/2              | 4  |
| VH0493 | BRONZE SLEEVE BEARING            | 1  |
| VH0494 | RETAINING RING                   | 1  |
| VH0496 | O-RING 030                       | 1  |
| VH0497 | E-RING                           | 1  |
| VH0498 | PIN, SLOTTED SPRING, 3/32 x 3/4  | 2  |
| VH0499 | PIN, DOWEL, 3/16 x 1/2           | 2  |
| VH0500 | PIN, SLOTTED SPRING, 1/8 x 11/16 | 3  |
| VH0506 | SPRING                           | 1  |
| VH0641 | O-RING, #218                     | -  |

USE LOCTITE 2760

| REV | DESCRIPTION | BY | APPD | DATE | MATERIAL:       | TOL. UNLESS SPECIFIED   | © 2008          | VERTEX FASTENERS INC.                         |
|-----|-------------|----|------|------|-----------------|---|-----------------|---|
|     |             |    |      |      |                 | INCHES<br>.X = ± .030<br>.XX = ± .015<br>.XXX = ± .005<br>ANGLES ± 1/2° | DWN BY JMW      | 3714 JARVIS AVENUE<br>SKOKIE, IL 60076 U.S.A. |
|     |             |    |      |      | HEAT TREATMENT: |   | APPD MR         | C-RING TOOL ASSEMBLY -<br>EXTENDED NOSE       |
|     |             |    |      |      | FINISH:         |   | DATE 8-13-08    |   |
|     |             |    |      |      |                 |   | SCALE           |   |
|     |             |    |      |      |                 |   | DWG. NO. VA0392 | C   |

THIS DOCUMENT AND THE DATA DISCLOSED HEREIN OR HEREWITH IS NOT TO BE REPRODUCED, USED, OR DISCLOSED IN WHOLE OR IN PART TO ANYONE WITHOUT THE PERMISSION OF VERTEX FASTENERS INC.

## RECOMMENDED SPARE PARTS LIST

| PART # | DESCRIPTION          | NO. OF TOOLS |    |    |
|--------|----------------------|--------------|----|----|
|        |                      | 1            | 5  | 10 |
| VC8100 | HOUSING              | 0            | 0  | 1  |
| VC8157 | BLADE, FEEDER        | 1            | 2  | 3  |
| VC8158 | SPRING, LATCH        | 1            | 2  | 4  |
| VC8103 | DEFLECTOR            | 0            | 1  | 2  |
| VC8139 | ROLLER               | 4            | 8  | 16 |
| VC8105 | SPOOL                | 0            | 1  | 2  |
| VC8106 | TRIGGER              | 1            | 2  | 3  |
| VC8107 | BUSHING, JAW         | 2            | 4  | 6  |
| VC8109 | SPRING, CF           | 1            | 2  | 4  |
| VC8110 | GUARD                | 0            | 1  | 2  |
| VC8111 | VALVE ROD            | 0            | 1  | 2  |
| VC8112 | MAGAZINE             | 0            | 1  | 2  |
| VC8113 | PUSHER               | 0            | 1  | 2  |
| VC8114 | SPRING, SHOE         | 2            | 4  | 6  |
| VC8115 | CLIP, ANTI-BACKUP    | 1            | 2  | 3  |
| VC8117 | SHIM, MAGAZINE, .010 | 2            | 8  | 12 |
| VC8119 | RAIL, FEEDER GUIDE   | 0            | 1  | 2  |
| VC8162 | PISTON               | 0            | 1  | 2  |
| VC8124 | SHOE, MAGAZINE       | 0            | 1  | 2  |
| VC8138 | ROD, PISTON          | 0            | 0  | 1  |
| VC8159 | LATCH                | 1            | 2  | 3  |
| VC8160 | JAW, UPPER           | 1            | 2  | 3  |
| VC8161 | JAW, LOWER           | 1            | 2  | 3  |
| VH0005 | O-RING, SPOOL        | 0            | 5  | 10 |
| VH0032 | SHCS, 10-24 X 1      | 2            | 2  | 4  |
| VH0033 | BHCS, 10-32 X 1/4    | 2            | 4  | 8  |
| VH0221 | WASHER               | 2            | 4  | 8  |
| VH0459 | PIN, SLOTTED SPRING  | 2            | 4  | 6  |
| VH0462 | O-RING, VALVE        | 5            | 10 | 20 |
| VH0464 | O-RING               | 0            | 2  | 4  |
| VH0486 | PAN HEAD, 6-19 X 1/4 | 1            | 2  | 4  |
| VH0488 | NUT, NYLOCK          | 2            | 4  | 8  |
| VH0489 | SHCS, 1/4-28 X 1 1/2 | 1            | 2  | 4  |
| VH0490 | NUT, NYLOCK          | 2            | 4  | 6  |
| VH0491 | BHCS, 10-24 X 1/2    | 2            | 4  | 8  |
| VH0493 | BUSHING              | 0            | 0  | 1  |
| VH0494 | RETAINING RING       | 0            | 0  | 1  |
| VH0641 | O-RING, PISTON       | 1            | 2  | 4  |
| VH0496 | O-RING               | 1            | 2  | 4  |
| VH0497 | E-RING, VALVE        | 0            | 1  | 2  |
| VH0498 | PIN, SLOTTED SPRING  | 1            | 2  | 4  |
| VH0499 | PIN, ROLLER          | 2            | 4  | 8  |
| VH0500 | PIN, ROLL            | 1            | 2  | 3  |
| VH0506 | SPRING, VALVE        | 0            | 1  | 2  |