

Service and Repair Instructions

Vertex Fasteners Pneumatic Stapler Type VA0262

This Spare parts list/service instructions and the enclosed operator's manual constitute the operating instructions. Read both before use and strictly observe safety instructions.

To replace worn and broken parts

Attention! Always disconnect the tool from its air supply and empty staple magazine. The cap has to be fixed with a torque wrench adjusted to 8 Nm.

To replace driver blade

Loosen cap VC7075 (fig. 1). Remove piston-driver blade assembly with a spare driver blade (fig. 2). With a pin punch tap out pin VC7330 (fig.3). The driver blade can then be removed. Replacement of the blade is a reversal of the above procedure.

Replacement of the piston O-ring

See instructions "to replace driver blade", then replace O-ring VC7326 (fig. 3), apply grease or oil before refitting.

After inserting the pin VC7330 the holes at both sides of the plastic piston have to be deformed again to prevent movement of the pin, which can then damage the cylinder. In order to do this, lay a drift punch, diameter 3mm, across the hole (fig.4) and hit the punch drift with a hammer so that the hole is deformed a little bit.

To replace bumper

See instruction "to replace driver blade", then remove bumper and cylinder. Before refitting grease the parts with O-ring grease or oil.

To replace tension spring and pusher

With a pin punch tap out pin VC7065 from the cover stop. Push the cover stop forward and remove, then remove rail assembly from the magazine cover. Hook new tension spring VC7063 onto feeder bar; lead it backwards under the pulley and over the hook inside the rail assembly (fig. 5).

To replace O-rings on valve system

Remove pin VC7329 and remove the trigger. Remove cap screw VC7365 to release valve cap (fig. 6). Remove valve gasket and tap out all components of the valve. Figure 7 shows a breakdown of the valve components, which are accessible once the valve cap has been removed. Replace the O-rings and grease, or oil before re-assembling.

To replace silencer

Remove cover as described above. Remove pin VC7065. Remove latch cover and leg spring. Take out silencer towards the rear and replace.

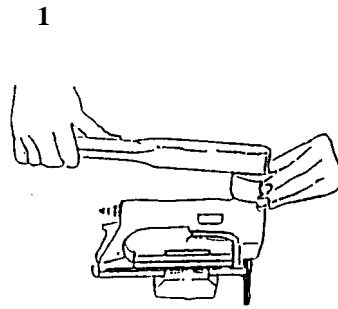

2

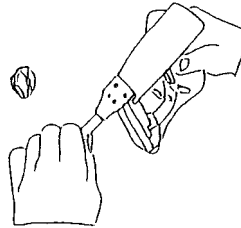

3

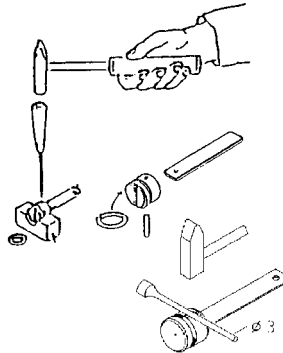

4

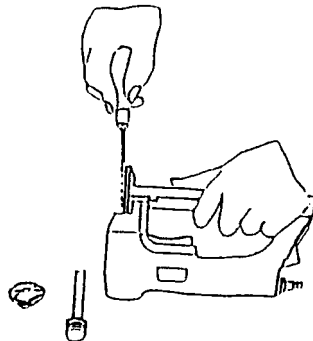

5

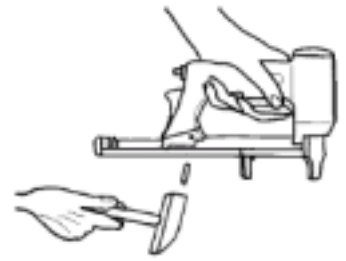

6



7

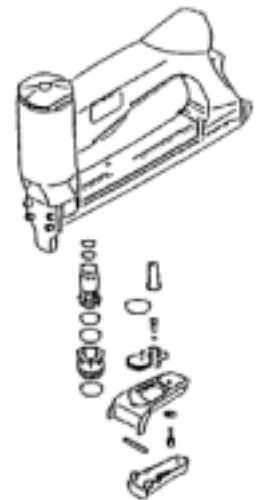

Parts Identification

Vertex Fasteners Pneumatic Stapler Type VA0262

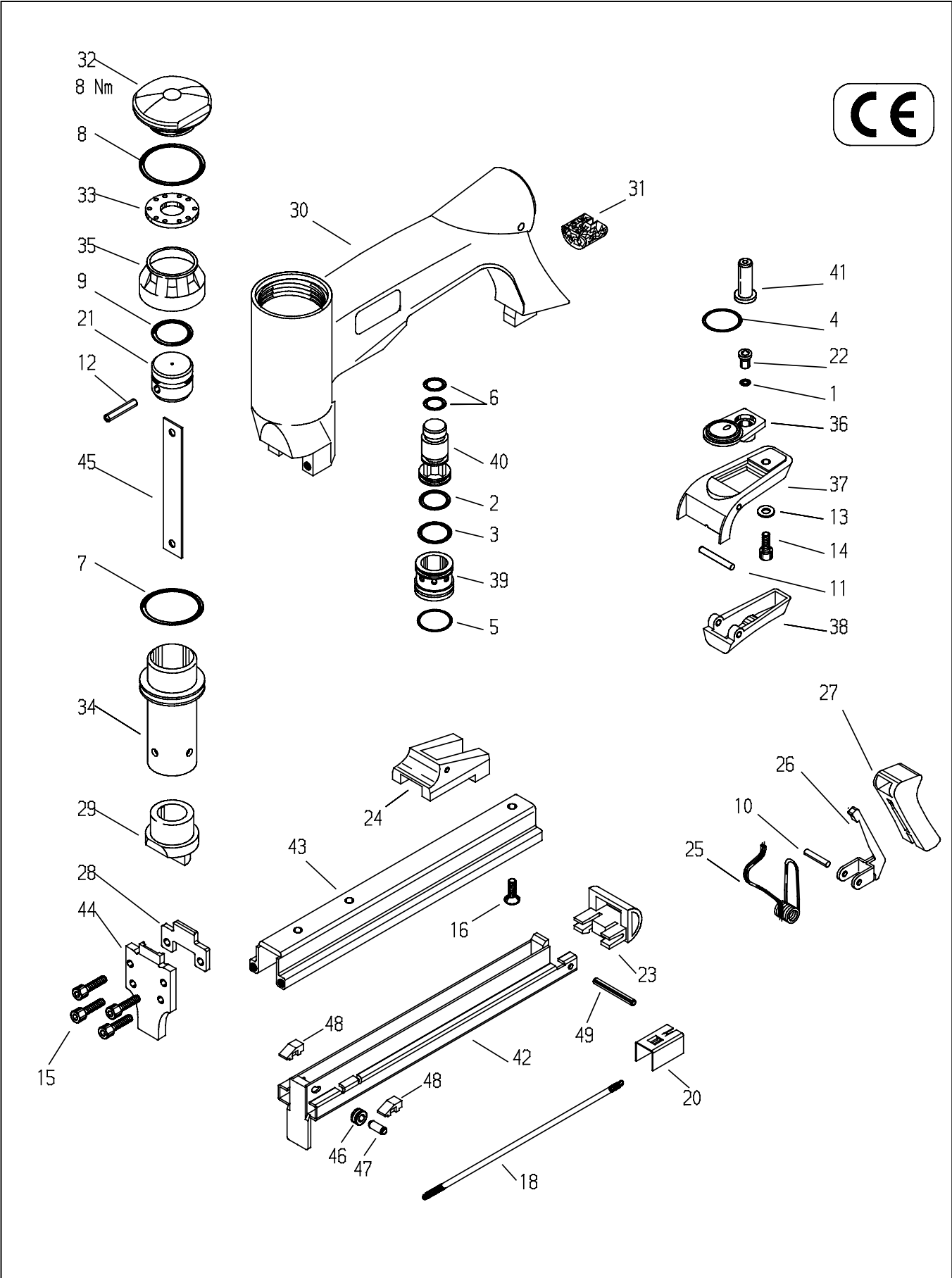

THIS DOCUMENT DRAWING IS STRICTLY THE SOLE AND PROPRIETARY PROPERTY OF VERTEX FASTENERS A LEGGETT & PLATT COMPANY. THE ENGINEERING AND DESIGN DATA PRINTED, WRITTEN, DISCLOSED AND CONTAINED HEREIN IS NOT TO BE REPRODUCED DISCLOSED OR USED IN WHOLE OR PART WITHOUT THE WRITTEN CONSENT AND PERMISSION FROM VERTEX FASTENERS.

Tool Parts

Vertex Fasteners Pneumatic Stapler Type VA0262

Call-out Number	Part Number	Description	Quantity
1	VC7276	O-ring	1
2	VC7280	O-ring	1
3	VC7281	O-ring	1
4	VC7292	O-ring	1
5	VC7300	O-ring	1
6	VC7307	O-ring	2
7	VC7311	O-ring	1
8	VC7313	O-ring	1
9	VC7326	O-ring	1
10	VC7065	Pin	1
11	VC7329	Pin	1
12	VC7330	Pin	1
13	VC7354	Washer	1
14	VC7365	Socket head cap screw	1
15	VC7390	Socket head cap screw	4
16	VC7389	Socket head flat screw	1
18	VC7063	Tension spring	1
20	VC7061	Pusher	1
21	VC7058	Piston	1
22	VC7059	Valve stem	1
23	VC7016	End piece	1
24	VC7013	Cover stop	1
25	VC7066	Leg spring	1
26	VC7067	Latch	1
27	VC7068	Latch cover	1
28	VC7070	Nose plate	1
29	VC7072	Bumper	1
30	VC7073	Body	1
31	VC7074	Muffler	1
32	VC7075	Cap	1
33	VC7076	Damper	1
34	VC7077	Cylinder	1
35	VC7078	Cylinder support	1
36	VC7079	Valve seal	1
37	VC7080	Valve cap	1
38	VC7081	Trigger	1
39	VC7082	Valve cylinder	1
40	VC7083	Valve shaft	1
41	VC7084	Intermediate valve	1
42	VC7085	Rail assembly	1
43	VC7086	Magazine cover	1
44	VC7087	Front nose	1
45	VC7088	Driver blade	1
46	VC7089	Pulley	1
47	VC7120	Pin	1
48	VC7014	Stop	1
49	VC7001	Split pin	1