

PART #	DESCRIPTION	QTY
VC0048	HOSE	1
VC0093	PIVOT MOUNT	1
VC0094	SWIVEL	1
VC0223	CLIP TRACK TUBE ASSEMBLY	1
VC0225	ARM	1
VC0227	FRAME BASE	1
VC0229	SPINDLE	1
VC0255	STEEL PIN	1
VC0256	UPPER HALF OF UPRIGHT	1
VC0257	LOWER HALF OF UPRIGHT	1
VC0268	TRACK ASSEMBLY 'A'	1
	VC0083 TRACK 'A'	1
	VC0085 TRACK GUIDE 'A'	14
	VH0042 SHCS, 8 - 32 x 1/4	28
	VH0043 LOCK NUT, 8 - 32	28
VH0021	RETRACTABLE HOSE 3/8	1
VH0038	SHOULDER BOLT, 5/16 x 1/2	2
VH0039	REGULATOR	1
VH0041	PRESSURE GAUGE	1
VH0042	SHCS, 8 - 32 x 1/4	2
VH0053	HHCS 1/2 - 13 x 3 1/4	4
VH0054	HEX NUT 1/2 - 13	4
VH0055	QCK DISCON. HOSE COUPLING	1
VH0056	NIPPLE 3/8 x 3	1
VH0057	ELBOW 3/8	2
VH0058	MALE CONN (COMP) 1/2 x 3/8	2
VH0060	SHCS, 5/16 - 18 x 3/4	2
VH0061	EYEBOLT 5/16 - 18 x 1 x 5/8	1
VH0062	HEX NUT 5/16 - 18	2
VH0064	TOOL BALANCER	1
VH0067	CAP	5
VH0086	SHCS, 1/4 - 20 x 1 1/4	1
VH0071	COUPLING, 3/8 NPT	1
VH0098	SPRING SNAP, 5/16	1
VH0120	SPLIT LOCK WASTHER, 5/16	2

1. TO INCREASE TENSION, APPLY WRENCH TO FLATS ON SHAFT AND ROTATE COUNTERCLOCKWISE.
2. TO DECREASE TENSION, APPLY WRENCH TO FLATS ON SHAFT AND HOLD, SQUEEZE TOGETHER SPRING LEVER ON OTHER SIDE OF REEL, THEN ROTATE WRENCH CLOCKWISE.

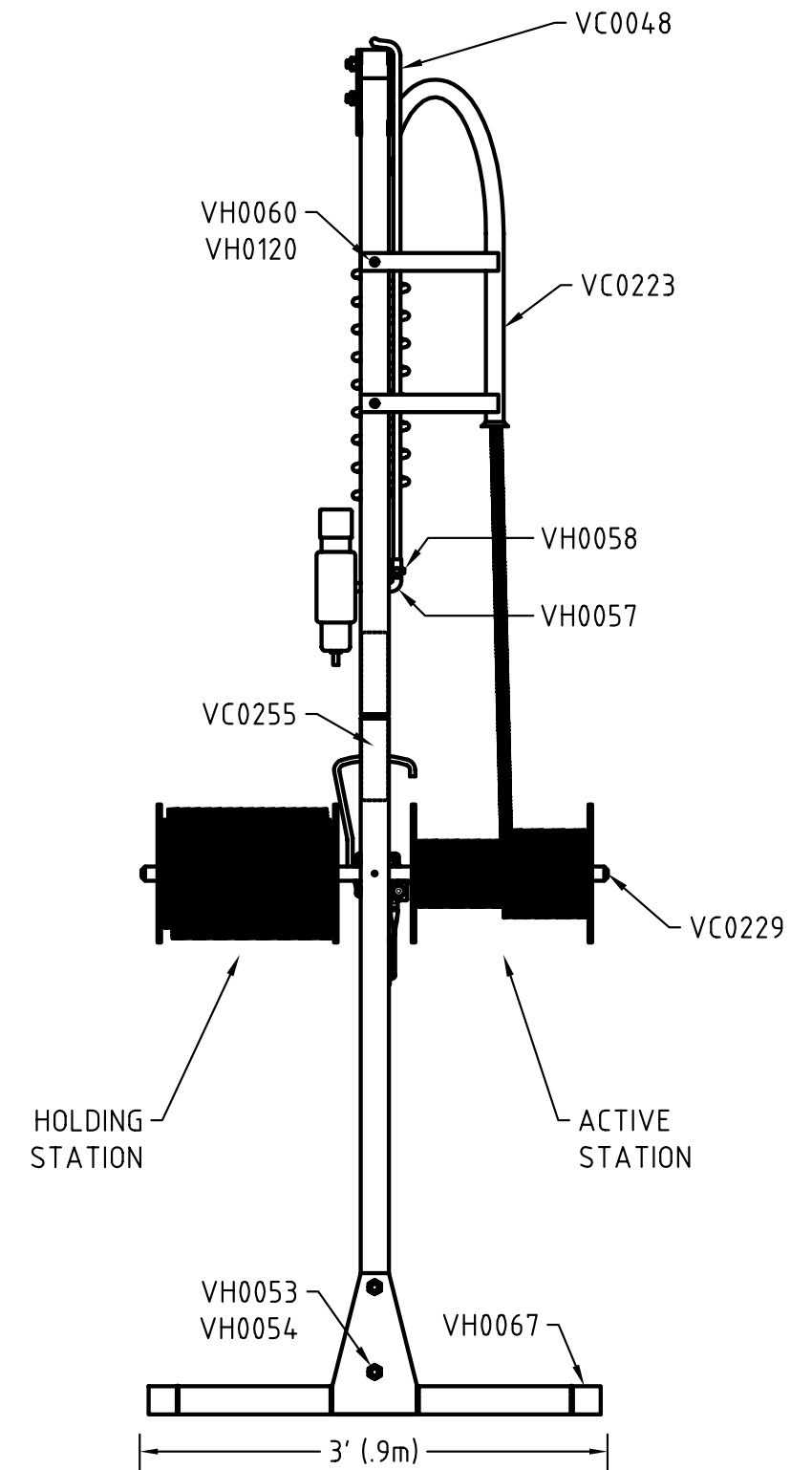
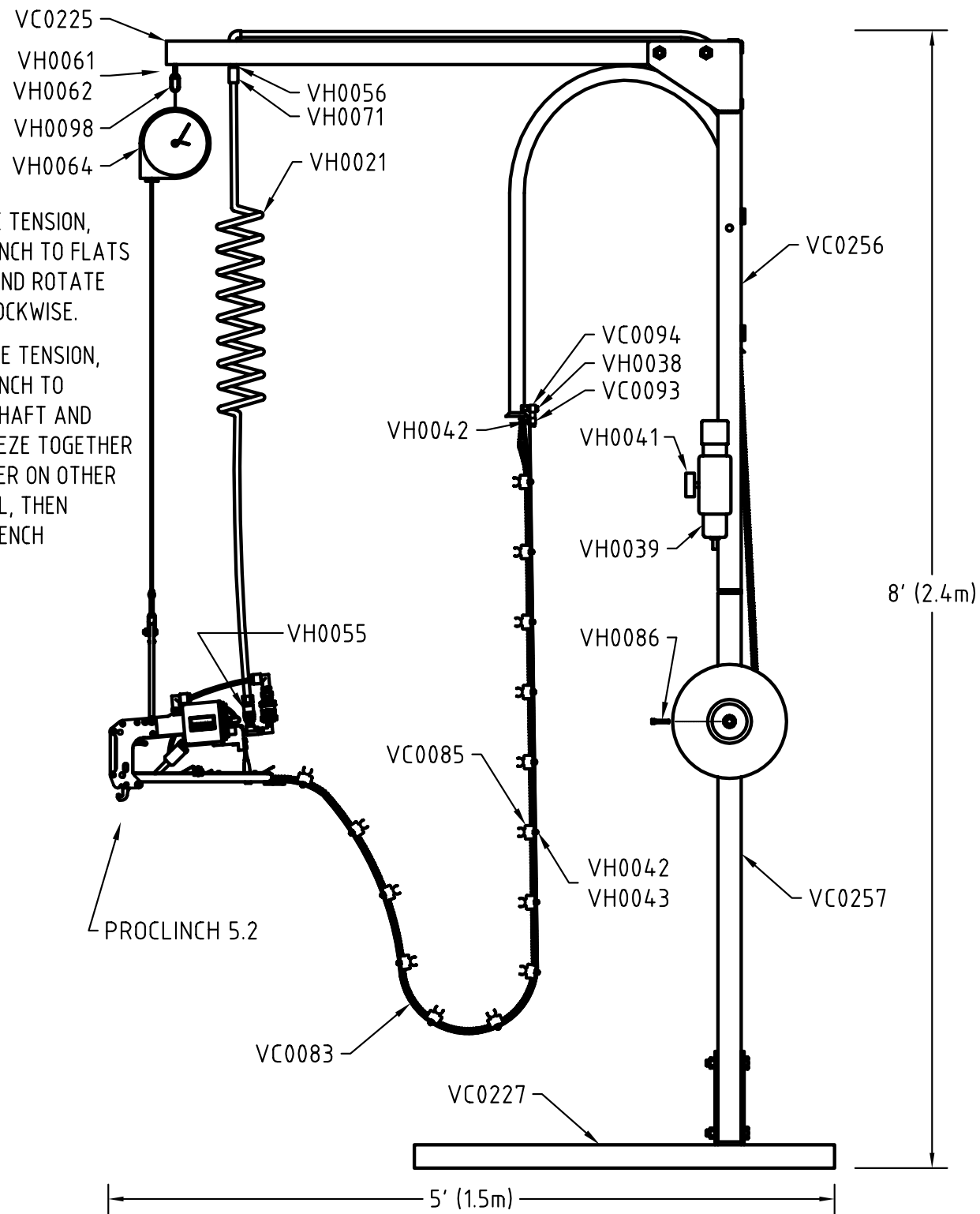

REV	DESCRIPTION	BY	APPD	DATE	© 2000	VERTEX FASTENERS INC. 3714 JARVIS AVENUE SKOKIE, IL 60076 U.S.A.
J	2000 FORMAT	JMW		7-17-00	DWN BY KH	
K	REMOVED EYEBOLT HOLES FOR TUBING	JMW		4-30-02	APPD	PROCLINCH FRAME ('A' CLIPS)
					DATE 6-16-97	
					SCALE NONE	
DWG. NO. VC2013K/VA0189K						B

ProCinch 5.2 SYSTEM